

### INTRODUCTION

The CH1840 is an ultra small, low profile Data Access Arrangement (DAA). Its modular construction and single +5 Volt D.C. power requirement simplify your development process. Specifically designed for both voice and data, this device allows direct connection of these circuits to the telephone lines. The CH1840 has FCC Part 68 registration that can be transferred to your product. Simply attach the included registration sticker to the outside of your product. This eliminates the costs and delays associated with Part 68 testing and registration.

The CH1840 has also been designed to meet the requirements of Canada's Department of Communication (DOC). However, it is necessary to register your product with the DOC before use in Canada.

The CH1840 requires only 1.5 square inches of circuit board space and presents a profile of only 0.35 inches in height. This DAA can either be mounted directly on a printed circuit board or socketed. Connection is made through 0.025 inch square pins on 0.10 inch centers. The telephone line connection is made through a user supplied RJ-11 jack.

The CH1840 DAA is designed for use with a variety of voice circuitry and LSI modem/fax chip sets. This device is ideal for fax and modem applications up through V.32bis. The CH1840 is pin compatible with the CH1817.

### FEATURES

- Works with all modem chip sets
- Available in 0 dB, -6 dB, and -9 dB insertion losses
- Available in extended temperature operation, -40°C to +85°C
- Complete DAA function
- Voice and data
- FCC Part 68 registered
- Registration conveyed to user
- Hook switch control
- Ring detection
- Single +5V operation
- Pulse dial capability

### FUNCTIONAL DESCRIPTION

The operation of the CH1840 can be broken down into the functional blocks shown in Figure 1.

- 1) Phone line control
- 2) Billing delay
- 3) Ring detection
- 4) Signal Path
- 5) 2- to 4-wire converter

Control inputs and status outputs for the CH1840 are compatible with 5 Volt CMOS. See the Electrical Specifications.

### Phone Line Control

In the Public Switched Telephone Network (PSTN), the wires from a telephone to the phone company's central office (CO) are referred to as the local loop.

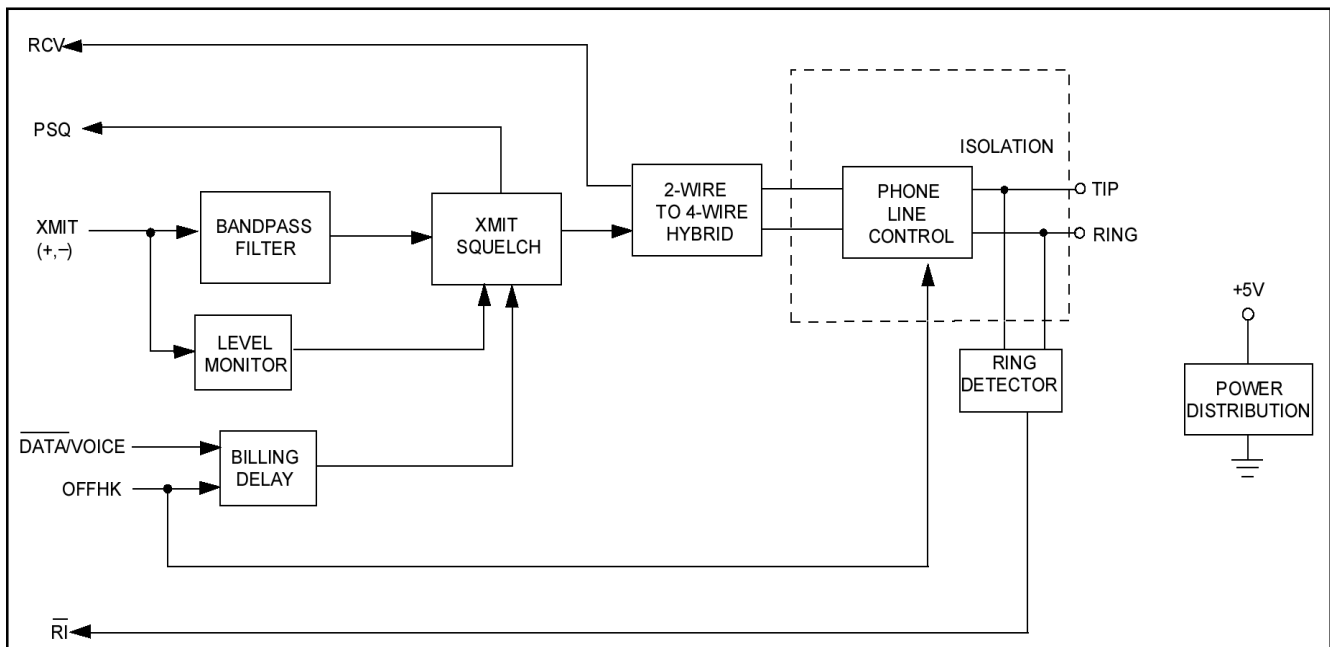

Figure 1. CH1840 Functional Block Diagram

Drawing current from the local loop signals the central office that the telephone is Off Hook, that is, either answering a call or preparing to place a call. In the CH1840, this function is controlled by the OFFHK signal. When this input is LOW, the CH1840 is On-Hook, indicating to the central office it is not using the line. The CH1840 can pulse dial by toggling the OFFHK input.

For data calls, FCC Part 68 rules require silence on the phone line for at least 2 seconds after the call has been completed to allow central office to exchange billing information. The CH1840 assures conformance to this requirement by starting a two-second timer on the LOW to HIGH transition to OFFHK and squelching transmitted signals until the time expires. The CH1840 defeats this function when Voice Mode is selected on the Data/Voice pin.

### Ring Detection

The central office signals an incoming call by placing a ring signal on the local loop. The CH1840 monitors the loop for this signal. The Ring\_Indication output, RI, is normally HIGH. When ringing appears, RI is set LOW during the typically 2 second ring period and is restored to HIGH for the typically 4 seconds between rings. The ring detection circuit is designed to prevent false indications due to noise or pulse dialing on the line.

The  $\overline{RI}$  output of the CH1840 is diode protected so that an external pull-up resistor ( $R > 100\text{Kohm}$ ) to +5V may be utilized to activate the ring detection circuit when the DAA is not connected to power. This can be handy with designs in which power consumption is of concern. When circuited in this manner, there is virtually no current draw until a ring signal is present. See Figure 3.

### Transmit Signal

The outgoing analog signal to be transmitted through the phone line should be applied to the XMIT pin (with respect to GND) and must be AC coupled, as shown in Figure 2. For the CH1840D, a XMIT(+) and XMIT(-) pin designation provides a differential input.

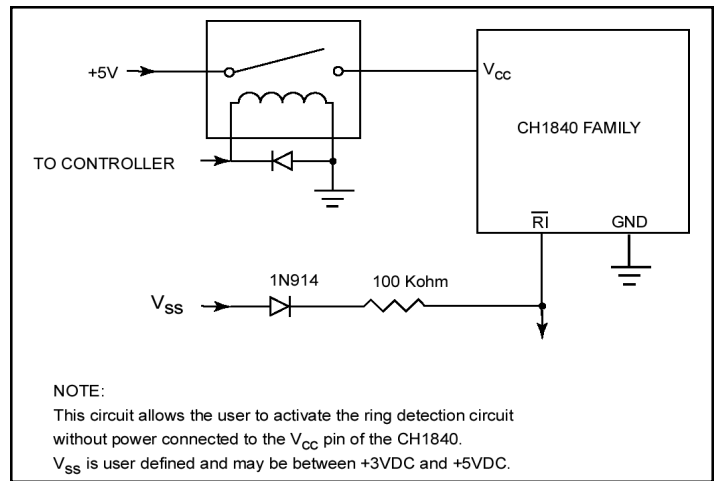

Figure 3. Low Power Ring Detection

The CH1840 attenuates the transmit signal by 9.5 dB, 0 dB for the D option). Thus, a transmit signal of 0 dBm for the CH1840 (-9.5 dBm for D) applied to XMIT will comply with the FCC Part 68 requirement for data signals of -9dBm across Tip and Ring. In all cases in the data mode, the CH1840 prevents the signal level from being greater than -9 dBm at Tip and Ring.

For live voice or DTMF, when the CH1840 family products are in voice mode, the output can be 0 dBm. In voice mode, the squelch will not let the output signal exceed 0 dBm. Hence, by applying a 0 dBm signal to the CH1840D and a +9.5 dBm signal to the CH1840, it will achieve the maximum signal output.

CH1840 Family	Nominal Insertion Loss
CH1840	-9.5 dB
CH1840D	0 dB

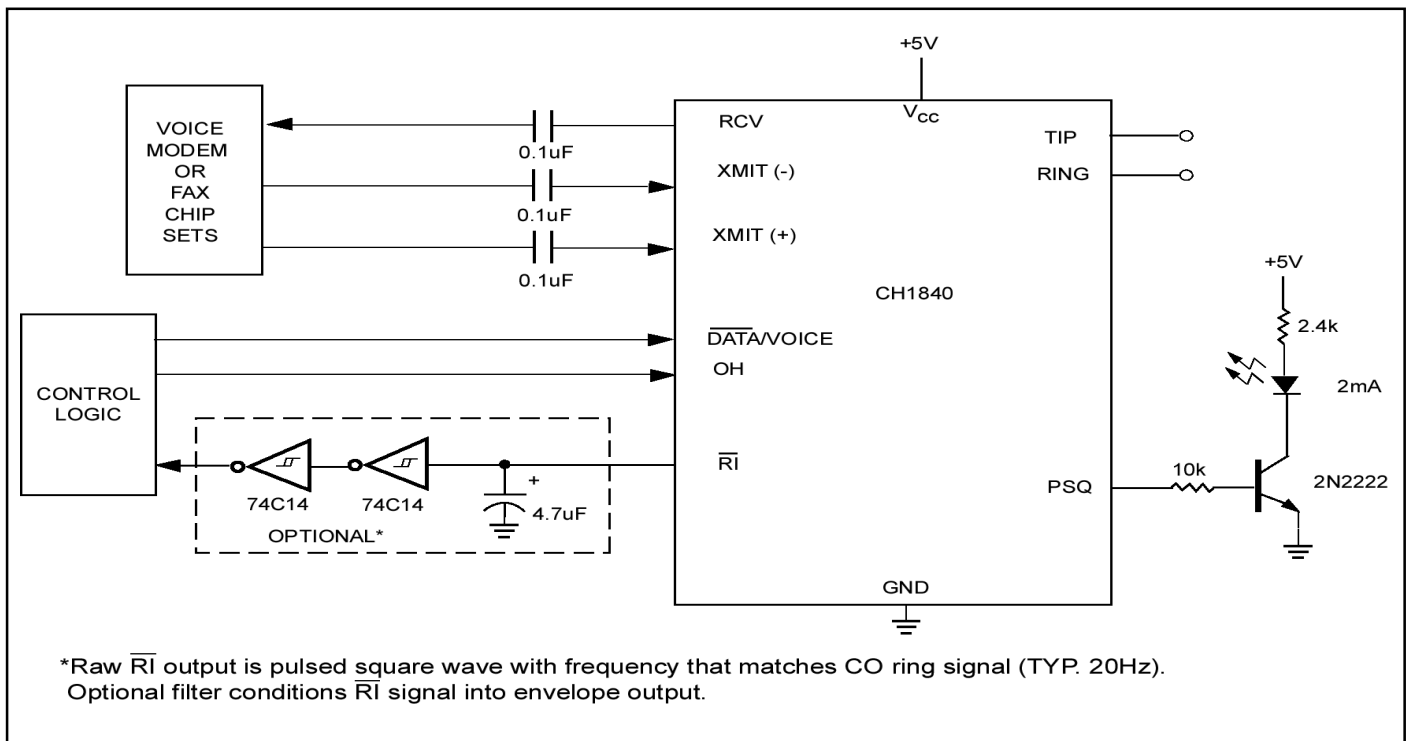

Figure 2. Typical Application

The D designation refers to differential input between the XMIT (+) and XMIT (-) pins. This is required and is a convenient input for certain types of modem chip sets.

### Receive Signal

Receive Signal is presented at RCV with respect to GND and must be AC coupled to your receive input. The CH1840 does not add any gain to the receive signal. Receive signals can vary from a maximum strength of -9 dBm to below -50 dBm for data mode and up to 0 dBm strength when DTMF and live voice are being received.

### Excessive Signal Detect

FCC Part 68 rules limit the average power of data signals transmitted to the phone line. To meet this requirement, the CH1840 monitors the transmit audio signal at XMIT. If the signal level exceeds 0 dBm, prior to the DAA attenuation, the transmit audio is prevented from reaching the phone line until the average input level is again below 0 dBm. The output PSQ is normally LOW. It is set HIGH when excessive power is detected and returns LOW when the transmitted signal is un-squelched.

Since FCC part 68 rules have no limitation to the signal strength of live voice transmission, the squelch feature is defeated when Voice mode is selected on the Data/Voice pin. The PSQ output always becomes inactive when the CH1840 is in Voice Mode. Note: When transmitting recorded or synthesized voice, the signal must be treated as Data per FCC; thus Data Mode must be selected on the Data/Voice pin.

### 2-Wire to 4-Wire Converter

This block has two functions: (1) it applies the XMIT signal to the phone line, (2) it subtracts this signal from the total signal on the phone to produce the received signal. The accuracy of this subtraction process depends on how closely the impedance of the phone line matches 600 ohms. Generally, a small amount of the XMIT signal will appear at RCV. The ratio of the XMIT signal applied to the signal returned is called trans-hybrid rejection. The CH1840 has a high trans-hybrid loss, which is at least 18-dB rejection from 300 Hz to 4 KHz bandwidth.

### VOICE SIGNALS

Voice signals are much more complex in nature than data signals. A voice signal is comprised of numerous frequencies combined at varying intensities. Whereas a data signal is comprised of no more than a few discreet frequencies. This difference dictates that voice signals receive more attention before connecting to the telephone lines.

The FCC restricts voice and data signals to between 300 Hz and 3300 Hz. This is because the telephone company uses frequencies below 300 Hz for low speed teletype and frequencies above 3300Hz for internal signaling and multiplexing.

Data signals easily meet the FCC requirements without additional filtering. However, bandpass filters are essential for voice communication.

A bandpass filter is utilized on the transmit line. This filter ensures that the signal meets FCC requirements. It also shapes the signal to minimize the phone line distortion.

**Table 1. Pin Description**

PIN	NAME	I/O	FUNCTION
1	TIP	I/O	TIP. Direct connection to the telephone line through a standard jack.
2	RING	I/O	RING. Direct connection to the telephone line through a standard jack.
3	N/C	-	Not Used. Please leave unconnected.
4	OFFHK	I	OFF HOOK, Input. When set Low, the CH1840 is placed on-Hook. When set HIGH, the CH1840 is placed Off-Hook to answer or place a call. This input can also be used for pulse dialing. NOTE: When answering incoming calls in response to a ring indication on RI, internal relay contact degradation may occur if OFFHK is set HIGH before RI returns to its HIGH state.
5	$\overline{\text{RI}}$	O	RING INDICATION, Output. RI is driven low during the typically 2-second ring period and HIGH during the typically 4 seconds between rings. RI is otherwise HIGH. NOTE: RI pulses square wave along with ring signal frequency. The square wave can be suppressed to produce an envelope of the AC ring with the application circuit shown in Figure 2.
6	$\overline{\text{D/V}}$	I	DATA/VOICE SELECT, Input. When driven LOW or left unconnected, Data mode is selected and the Billing Delay and Power Squelch are enabled. When driven HIGH, voice mode is selected and the Billing Delay and Power Squelch are disabled.
7	PSQ	O	POWER SQUELCH, Output. PSQ indicates the status of the signal limiting squelch circuit. When PSQ is HIGH, the transmit path is squelched. PSQ is also active when On-Hook and in Data Mode.
8	RCV	O	RECEIVE, Output. RCV is the audio signal received from the phone line. This output symmetrical with respect to +2.5C. AC coupling is recommended for most designs.
9	XMIT(-)	I	Input must be used with pin 11 in differential mode only. When not used, please leave unconnected.
10	VCC	I	+5V power Supply, Input.
11	XMIT(+)	I	TRANSMIT, Input. Analog signal input. Audio data and voice signals presented here will be monitored for excessive power, filtered through a bandpass, and applied to the phone line unless squelched. One input pin of two when used in differential mode with pin 9.
12	GND	I	SIGNAL and POWER COMMON GROUND, Input.

## SAMPLE APPLICATION

Figure 2 illustrates a typical application of the CH1840. When transmitting data the controller must assert the D/V pin low to provide the two second billing delay required by the FCC. When transmitting voice signals, the controller should drive the D/V pin high. This disables the billing delay, and power squelch.

One of the requirements of an FCC approved DAA is that the signal transmitted to Tip and Ring does not exceed -9.0 dBm. The CH1840 incorporates an automatic squelch. If the signal exceeds -9.5 dBm, the DAA will discontinue transmission until the signal returns to acceptable levels. The PSQ output indicates when the squelch circuit has been activated. By utilizing PSQ to drive the illustrated LED circuit, a visual indication of the squelch activation can be attained.

## DESIGN CONSIDERATIONS

The following guidelines for your product design must be followed to meet the requirements of FCC Part 68 rules.

- 1) The mounting of the DAA in the final assembly must be made so that it is isolated from exposure to any hazardous voltages within the assembly. Adequate separation and restraint of cables and cords must be provided.
- 2) The circuitry from the registered unit to the telephone line must be provided in wiring that carries no other circuitry than that specifically allowed in the rules ( such as A and A1 leads).
- 3) See Section "For Your User's Manual" for information that must appear in your User's Manual.
- 4) Connection to the phone line should be made through a standard RJ-11C jack or equivalent.
- 5) Circuit board traces from the CH1840's TIP and RING pins must exceed 0.1 inch spacing to one another and 0.2 inches spacing from all other traces or other conducting material. Traces should have a nominal width of 0.020 inches or greater.

6) TIP and RING traces should be as short as possible and should be oriented to prevent direct or induced coupling with other signals on the host circuit card.

7) No additional application circuitry should be connected between the CH1840 and the phone line RJ-11C jack, except as described in note 10 below.

8) The registration label included with the product must be affixed to the outside of your product where it is easily visible to your end user.

9) The CH1840 Module is a sensitive subsystem that should be treated as any other integrated component. Pay special attention to the power supply to the DAA. The device handles signals in the millivolt range. Although it is designed to handle noise in the power supply, steps should be taken to assure the noise level does not exceed 50 mV peak-to-peak. Failure to provide such operating conditions could cause the CH1840 to malfunction.

10) The CH1840 DAA meets or exceeds the hazardous voltage, surge and leakage requirements of the FCC. For applications that connect to Canadian phone lines, governed by the DOC (Department of Communications) and to further protect the CH1840 from field failure due to poor lines, a higher level of transient protection is required, thereby making mandatory the circuit consisting of two fuses and one varistor as shown in Figure 4. Adding these three devices will not affect FCC or U.L. registration.

Components L1, L2, C1, C2 are optional and serve two purposes. First, they restrict high frequency signals from reaching the phone line and thereby add EMI protection. Second, they protect against externally generated RFI from degrading the modem's ability to operate on proper carrier signals. Adding these devices will not affect FCC, DOC, or U.L. registration.

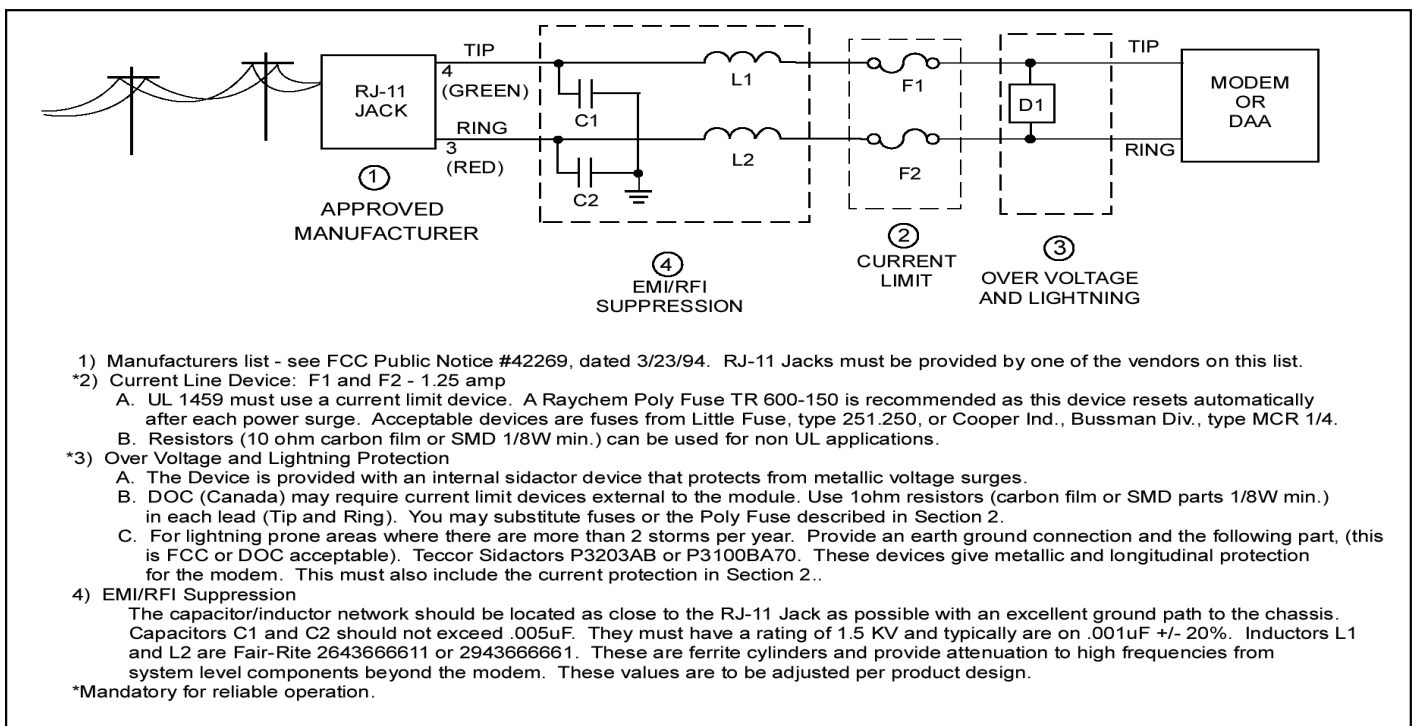

Figure 4. Telephone Line Interfaces

---

## Mounting the CH1840

The CH1840 can be soldered directly to the host circuit card or installed in sockets. Direct soldering provides the most sound connection. To avoid the problems of flux contamination, hand soldering is preferred to wave soldering. Many socket manufacturers offer socket strips that accept the 0.025 inch square pins on 0.10 inch centers. When using mechanical sockets, restraint of the CH1840 should be provided to keep it seated during shipment. Plastic cablewraps are secure yet easily removed.

## FOR YOUR USER'S MANUAL

The Part 68 rules require the following or the equivalent information be provided to the end user of equipment containing a DAA:

## FCC NOTICE TO THE USERS

1. UPON REQUEST ONLY, you must provide the following data to your telephone utility company (telco):
  - a) Notice of intention to install or permanently remove an FCC Part 68 registered device or system, and the \*FCC Registration Number.
  - b) \*The Ringer Equivalence Number (REN) (see device label). Note that if several devices are connected to the same line, the RENs must not add up to more than 5.0 (A or B). This REN figure is important to your telco.
  - c) \*The (USOC) jack type to be provided by the telco. Typically this will be RJ-11C/W for single lines.

*\*The \*-flagged items above are noted on the equipment's FCC Compliance label.*

2. This device may not be used on telco-operated coin phone lines. Party lines and privately owned coin-phones are subject to local State regulatory policies, and possible additional State special requirements.
3. The telco has the right to make changes to its network which may affect the operation of your equipment, provided you are given adequate advance written notice to permit correct operation.
4. In case of operational problems, disconnect your unit by removing the modular plug from the telco jack. If your regular phone (or other device or system) still works properly, your [product name] has a problem and must remain disconnected and (officially) serviced or returned for repairs. If upon the above connection, your regular service still has problems, notify your telco that they may have a problem. Request prompt service at no cost to you the user. If a problem is found in premises wiring not telco-installed, you are subject to a service charge. If a fault is in telco-installed wiring, you may be subject to a service call charge.
5. Unless otherwise noted in the User's Manual (e.g.: fuses, etc.), user may not under any circumstances (in or out of warranty) attempt any service, adjustments or repairs on this unit. It must be returned to the factory or authorized U.S. service agency for all such work. Locations (or phone numbers) of factory or authorized U.S. service points are listed in this user's manual.
6. Special FCC rules apply to equipment connected behind a PBX or KTS.
7. Changes in Attestation Procedure for Plugs and Jacks: (Name of applicant) attests that the network interface plugs or jacks used on this equipment comply with and will continue to comply with the mechanical requirements specified in Part 68, Subpart F, specifically the dimensions, tolerances and metallic plating requirements. The compliance of these connectors will be assured by purchase specifications and incoming inspection. Documentation of such specifications and/or inspections will be provided by the FCC within 30 days of their request for the same.

**Table 2**  
**CH1840 DAA Electrical Specifications**  
 $T_A = 0^\circ\text{C}$  to  $55^\circ\text{C}$  unless otherwise specified  
 Extended Temperature (ET) versions available to  $T_A = -40^\circ\text{C}$  to  $+85^\circ\text{C}$

PARAMETER	SYMBOL	CONDITIONS	MIN.	TYP.	MAX.	UNITS
LOGIC Input high Input low Input leakage high Input leakage low Output high Output low	$V_{IH}$ $V_{IL}$ $I_{IH}$ $I_{IL}$ $V_{OH}$ $V_{OL}$	$I_{OH} = 0.2\text{mA}$ $I_{OL} = 2.0\text{mA}$	3.0 -0.3		5.0 0.8 500 -500	V V uA uA V V
Telephone Line Interface AC Impedance	$Z_{LINE}$		600			Ohms
Isolation Protection		Conforms to FCC Part 68 hazardous voltage and leakage	1K			$V_{RMS}$
Surge Protection		Conforms to FCC Part 68 for surge	800			$V_{peak}$
Transmit Level	$V_{TRX}$	Measure at XMIT, 1800 Hz CH1840 (Voice Mode) CH1840D			0.774 0.251	$V_{RMS}$ $V_{RMS}$
Transmit Insertion Loss	$G_{TRX}$	1800 Hz, 600 Ohms, 35mA loop current CH1840 (Voice Mode) CH1840D	9.5 -0.5	10 0.0	10.5 0.5	dB dB
Receive insertion Gain	$G_{RCV}$	1800 Hz, 600 Ohms, 35mA loop current	-0.5	0	+0.5	dB
Trans-hybrid loss	$G_{TH}$	600 Ohms +3% between TIP & RING 600 Hz to 4000 Hz	18	23		dB
On-Hook Impedance	$Z_{ONHK}$	OFFHK = 0 volts	10	20		Mohm
Loop Current	$I_{LOOP}$	OFFHK = 5 volts	20		80	mA
Receive Output Impedance	$Z_{RNC}$	Measured at RCV			50	mA
Transmit Input Impedance	$Z_{TRX}$	Measured at XMIT @ 1800 Hz	50	100		Kohm
FCC Registration Number		Supplied on unit label				
Ringer Equivalence	REN	Supplied on unit label		0.2A		REN
TIMERS Ring Detection Delay Billing Delay Timer	$T_{RGD}$ $T_{BD}$	Ring at 40 Hz, 45 $V_{RMS}$	2.0	200 2.5	360 3.0	ms sec
Hook Switch				0.5	1.0	mA
Power Supply Current	$I_{CH5}$	+5V $\pm 5\%$ Supply Voltage Off Hook On Hook		6 3	10 6	mA mA

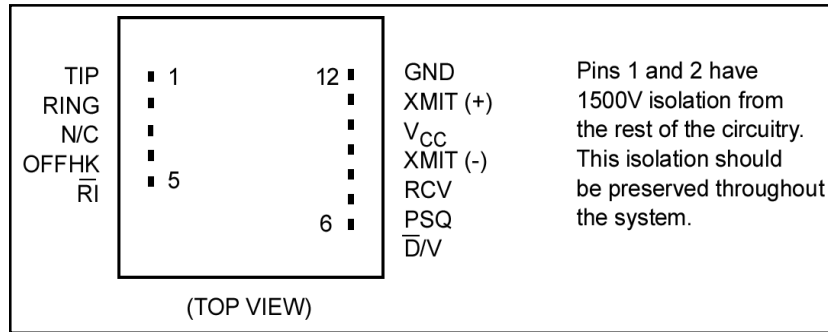

**Figure 5. Pin Connections**

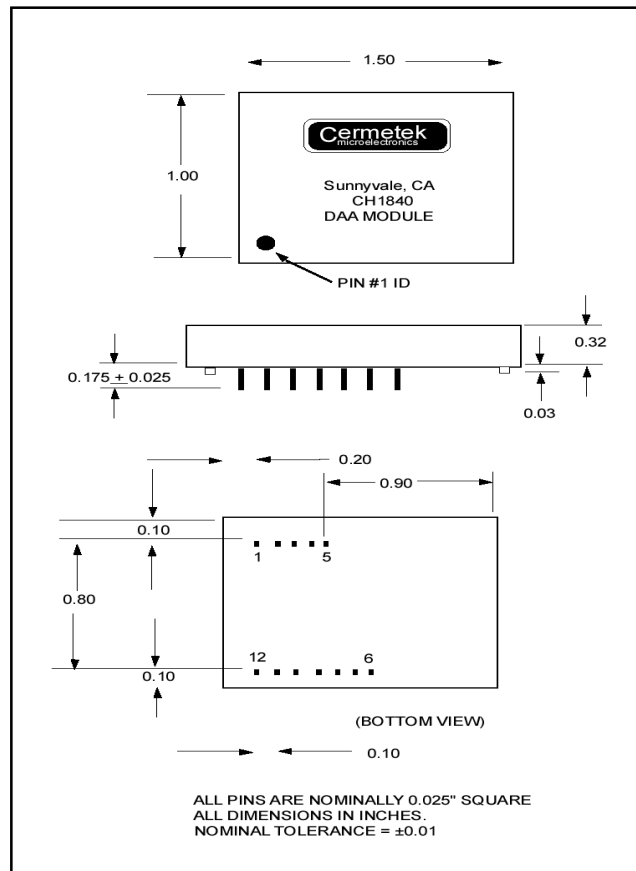

**Figure 6. Mechanical Specifications**



406 TASMAN DRIVE · SUNNYVALE, CALIFORNIA 94089 · TEL: (408) 752-5000 FAX: (408) 752-5004  
E-mail: [cermstaf@cermetek.com](mailto:cermstaf@cermetek.com)  
website: [www.cermetek.com](http://www.cermetek.com)

Cermetek reserves the right to make changes in specifications at any time and without notice. The information furnished by Cermetek in this publication is believed to be accurate and reliable. However, no responsibility is assumed by Cermetek for its use, or for any infringements of patents or other rights of third parties resulting from its use. No license is granted under any patents or patent rights of Cermetek.